

IX2127
Design Considerations

1 High-Side Gate Driver Using the IX2127

This application note provides general guidelines for designing a desaturation detection circuit, and selecting bootstrap components for use with IXYS Integrated Circuits Division's IX2127.

The IX2127 is a high-voltage, high-speed driver optimized to drive IXYS high voltage power MOSFETs and IGBTs. The IXYS high voltage SOI process and the IX2127 high voltage level shifters allow this driver to

operate at up to 600V. In addition, proprietary common mode techniques insure stable operation in high dV/dt noise environments.

The IX2127 features an on-board comparator that detects an over-current condition in the external power switch, and then terminates the drive to that switch. An open drain output, FAULT, indicates to the system controller that an over-current shutdown has occurred.

Figure 1 IX2127 Block Diagram

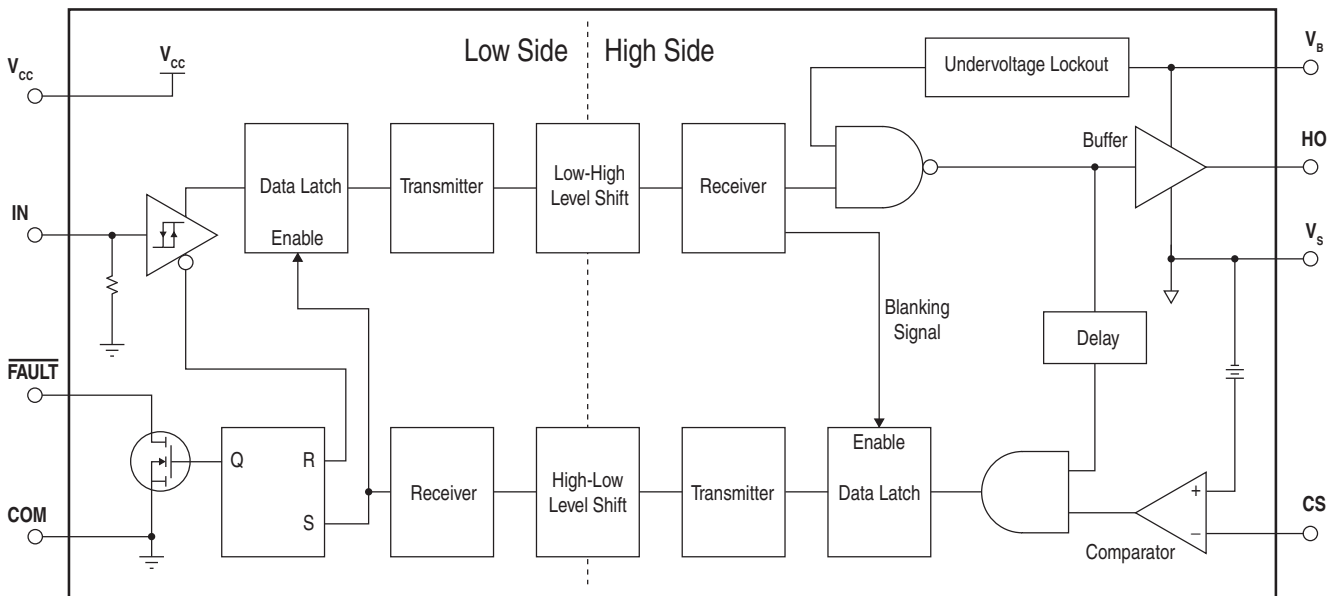
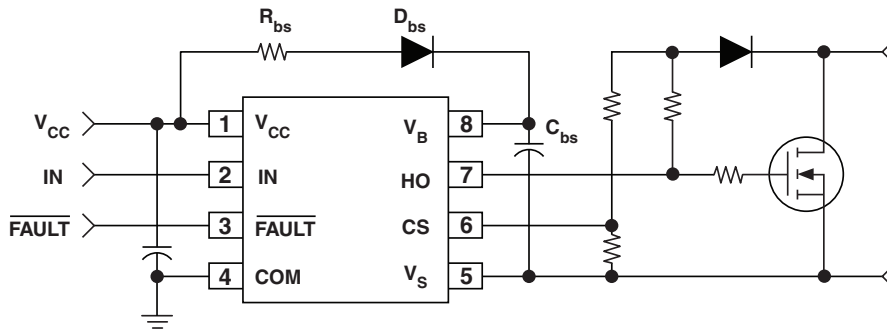

Figure 2 Application Circuit Diagram



2 Simple Bootstrap Circuit Operation

The bootstrap circuit is a simple and inexpensive way to provide power to the high side driver circuitry. It consists of resistor, diode and capacitor. The sequence of bootstrap charging is as follows. When V_S is pulled below V_{CC} or is pulled down to ground by the load, the bootstrap capacitor begins to charge through the resistor and bootstrap diode from the V_{CC} supply. This charge continues until V_S is pulled up to a higher voltage than V_{CC} by the external high side power MOSFET. V_{BS} (the difference voltage between V_B and V_S) starts to float, and the bootstrap diode begins to reverse bias and block the high rail voltage.

3 Bootstrap Capacitor

The bootstrap capacitor is selected based on the maximum allowable voltage drop when the high side switch is on. This voltage is determined by the power MOSFET's minimum V_{GS} voltage which is required to keep the high-side switch turned on, a parameter usually given in the MOSFET datasheet. The capacitor voltage drop can be expressed by:

$$\Delta V_{boot} \leq V_{CC} - (V_{fbs} + V_{GS(min)})$$

Where:

- V_{CC} = Supply voltage
- V_{fbs} = Bootstrap Diode Forward Voltage Drop
- $V_{GS(min)}$ = Minimum Gate to Source Voltage of Power MOSFET

The minimum value of the bootstrap capacitor is given by the formula:

$$C_{bs} = Q_{total} / \Delta V_{boot}$$

Where Q_{total} is the total amount of charge supplied by the capacitor.

The total charge can be expressed as follows:

$$Q_{total} = Q_g + [I_{lkcap} + I_{lks} + I_{qbs} + I_{lk} + I_{Cbs(leak)}] \times t_{on} + Q_{ls}$$

Where:

- Q_g = Total gate charge of power MOSFET or IGBT
- I_{lks} = MOSFET gate to source leakage current (given in MOSFET datasheet as I_{GSS})
- I_{lkcap} = Bootstrap capacitor leakage current (can be ignored if a ceramic capacitor is used)
- I_{qbs} = Bootstrap circuit quiescent current
- I_{lk} = Bootstrap circuit leakage current
- Q_{ls} = Charge of IX2127 internal level shifter (5nC)
- t_{on} = High-side switch-on time
- $I_{Cbs(leak)}$ = Bootstrap leakage current

The bootstrap capacitor voltage is determined by the V_{CC} power supply, and in this case a 25V to 50V capacitor should be adequate.

Note that the leakage current in a ceramic capacitor is very low, and can be ignored in most calculations. The use of electrolytic capacitors is strongly discouraged due to their contribution of excessive leakage currents at higher temperatures.

3.1 Example:

Calculate the bootstrap capacitor value based on the following circuit components, an operating frequency of 20 kHz, and at a Duty Cycle of 50%:

- IXTA5N60P - Power MOSFET
- MURS160-13-F- Bootstrap Diode
- $V_{CC} = 12V$
- $Q_{gate} = 14.2nC$ maximum
- $I_{lkgS} = 100nA$ maximum

- $I_{lk\ cap} = 0$
- $I_{qbs} = 1000uA$
- $I_{lk} = 50uA$
- $Q_{Is} = 5nC$
- $t_{on} = 25uS$
- $I_{Cbs(leak)} = 10nA$

If the maximum allowable voltage drop on the capacitor is 1V during the high-side switch-on state, then the minimum capacitor value can be calculated:

$$Q_{total} = (14.2 \times 10^{-9}) + [100 \times 10^{-9} + 1 \times 10^{-3} + 50 \times 10^{-6} + 10 \times 10^{-9}] \times (25 \times 10^{-6}) + (5 \times 10^{-9})$$

$$= 31.25nC$$

The value of the bootstrap capacitor is:

$$C_{bs} = Q_{total} / \Delta V_{boot} = 31.25nC / 1V = 31\ nF$$

Note that the voltage drop of the bootstrap diode contributes about 0.8V to the total voltage drop

The value obtained from the above equation is the absolute minimum required. In some cases, though, a low value capacitor can cause overcharging and ripple on V_{bs} so the value obtained from the equation should be evaluated in an application circuit, and increased if required.

4 Bootstrap Resistor

The bootstrap resistor, R_{bs} , can be used to control charging current into the bootstrap capacitor. The value of this resistor has to be selected very carefully so that the bootstrap capacitor is able to charge fully under all operating conditions.

This resistor will introduce a voltage drop that can be approximated with this formula:

$$V_{drop} = (I_{chg} - R_{bs}) / t_{chg}$$

Where,

- I_{chg} = Bootstrap capacitor charging current
- R_{bs} = Bootstrap resistor
- t_{chg} = Bootstrap capacitor charging time

In practice R_{bs} will be a small value of up to 10Ω. Let's look closer at the time constant that depends on R_{bs} , C_{bs} , and the duty cycle, D, of the switching power switch.

$$\tau = (R_{bs} \times C_{bs}) / D$$

For instance, if $R_{bs} = 3\Omega$, $C_{bs} = 0.1\mu F$, and $D = 10\%$, then the time constant can be evaluated:

$$\tau = (3 \times 0.1) / 0.1$$

$$= 3\mu s$$

5 Bootstrap Diode

The bootstrap diode provides a voltage-charging path for the bootstrap capacitor, and also serves to block the full power rail voltage. This diode must have a very fast recovery time in order to minimize the amount of charge injected back from the bootstrap capacitor to V_{CC} . Here are some parameters that should be looked at when selecting this diode:

- V_{rrm} = Power Rail Voltage
- $t_{rr} = 100nS$ or less
- $I_f = Q_{total} \times$ Frequency

Note that reverse recovery time (t_{rr}) is a function of the forward diode current.

6 Desaturation Detection Circuit

The voltage across the MOSFET will increase during an over-current condition; hence, we can use a basic circuit consisting of R_1 , D_2 , R_2 and R_3 to detect this overload condition.

R_1 is selected to be 10kΩ. This value minimizes Miller capacitance from D_2 , and ensures that there is no significant current being drawn from the high-side HO output pin. Due to the presence of the high voltage rail, D_2 can be the same as D_{BS} .

6.1 Example:

Calculate component values in the event of an 8V overload condition (use the circuit in **Figure 3**):

This calculation is based on a D_2 maximum voltage drop of 1.2V. The voltage at V_A can be expressed as:

$$V_A = V_{diode} + V_{DS}$$

$$V_A = 1.2V + 8V$$

$$V_A = 9.2V$$

The CS threshold is 260mV; hence, we need to divide V_A so that when $V_A=9.2V$, then $V_X=260mV$.

Let $R_2=33k\Omega$, and Solve for V_X :

$$V_X = V_A \times [R_3 / (R_2 + R_3)]$$

$$0.26V = 9.2V \times [R_3 / (33k\Omega + R_3)]$$

$$0.26V \times (33k\Omega + R_3) = 9.2V \times R_3$$

$$8580\Omega + 0.25V \times R_3 = 9.2V \times R_3$$

$$8580\Omega = 8.94 \times R_3$$

$$R_3 = 960\Omega$$

Figure 3 Saturation Detection Circuit

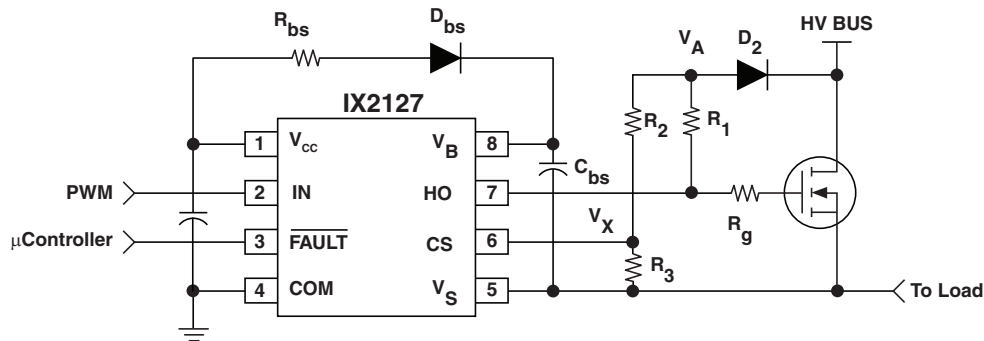

7 Gate Resistor

R_g is the gate resistor, which is chosen to optimize switching speed and losses. Let's select a gate resistor that will provide 100ns switching time at $12V_{CC}$. In this example case, the IXTA5N60P MOSFET is selected.

From the IXTA5N60P and IX2127 datasheets we get the following parameters:

- $V_{CC}=12V$
- $Q_{gs}=4.8nC$
- $Q_{gd}=4.8nC$
- $V_{gs(th)}=5.5V$
- $t_{SW}=100ns$

We define average gate current as:

$$I_{gate(avg)} = (Q_{gs} + Q_{gd}) / t_{SW}$$

$$I_{gate(avg)} = (4.8nC + 4.8nC) / (100ns)$$

$$= 0.096A$$

The total resistance can be expressed:

$$R_{total} = (V_{CC} - V_{gs(th)}) / I_{gate(avg)}$$

$$R_{total} = (12V_{CC} - 5.5V_{gs(th)}) / 0.096A$$

$$= 68\Omega$$

The driver-on resistance can be approximated:

$$R_{driver(on)} = V_{CC} / I_{OH+}$$

Typical I_{OH+} is listed as 250mA in the IX2127 data sheet.

$$R_{driver(on)} = 12V_{CC} / 250mA$$

$$= 48\Omega$$

The difference of R_{total} and $R_{driver(on)}$ will yield a 20Ω resistor that will provide 100ns switching time at $12V_{CC}$.

8 Layout Considerations

Proper layout techniques are important when designing high-speed gate drivers. The decoupling capacitors,

the bootstrap resistor, and the gate resistor, R_g , should be close to the gate driver.

For additional information please visit our website at: www.ixysic.com

IXYS Integrated Circuits Division makes no representations or warranties with respect to the accuracy or completeness of the contents of this publication and reserves the right to make changes to specifications and product descriptions at any time without notice. Neither circuit patent licenses nor indemnity are expressed or implied. Except as set forth in IXYS Integrated Circuits Division's Standard Terms and Conditions of Sale, IXYS Integrated Circuits Division assumes no liability whatsoever, and disclaims any express or implied warranty, relating to its products including, but not limited to, the implied warranty of merchantability, fitness for a particular purpose, or infringement of any intellectual property right.

The products described in this document are not designed, intended, authorized or warranted for use as components in systems intended for surgical implant into the body, or in other applications intended to support or sustain life, or where malfunction of IXYS Integrated Circuits Division's product may result in direct physical harm, injury, or death to a person or severe property or environmental damage. IXYS Integrated Circuits Division reserves the right to discontinue or make changes to its products at any time without notice.

Specification: AN-400-R03
©Copyright 2013, IXYS Integrated Circuits Division
All rights reserved. Printed in USA.
6/24/2013